

## FCC Test Report

**Report No.:** FD200316D06

**Test Model:** DMX-110

**Series Model:** DMX-1 XXXXXXXXXXXXXXXX ("X" can be 0-9, A-Z or blank for marketing purpose)

**Received Date:** Mar. 16, 2020

**Test Date:** Mar. 19 to 20, 2020

**Issued Date:** Apr. 1, 2020

**Applicant:** Vecow Co., Ltd.

**Address:** 3F., No.10, Jiankang Rd., Zhonghe Dist., New Taipei City 23586, Taiwan

**Issued By:** Bureau Veritas Consumer Products Services (H.K.) Ltd., Taoyuan Branch  
Lin Kou Laboratories

**Lab Address:** No. 47-2, 14th Ling, Chia Pau Vil., Lin Kou Dist., New Taipei City, Taiwan

**FCC Registration/  
Designation Number:** 418586 / TW1078



This report is for your exclusive use. Any copying or replication of this report to or for any other person or entity, or use of our name or trademark, is permitted only with our prior written permission. This report sets forth our findings solely with respect to the test samples identified herein. The results set forth in this report are not indicative or representative of the quality or characteristics of the lot from which a test sample was taken or any similar or identical product unless specifically and expressly noted. Our report includes all of the tests requested by you and the results thereof based upon the information that you provided to us. You have 60 days from date of issuance of this report to notify us of any material error or omission caused by our negligence, provided, however, that such notice shall be in writing and shall specifically address the issue you wish to raise. A failure to raise such issue within the prescribed time shall constitute your unqualified acceptance of the completeness of this report, the tests conducted and the correctness of the report contents. Unless specific mention, the uncertainty of measurement has been explicitly taken into account to declare the compliance or non-compliance to the specification. The report must not be used by the client to claim product certification, approval, or endorsement by A2LA or any agency of the U.S. government. The report must not be used by the client to claim product certification, approval, or endorsement by TAF or any government agencies.

## Table of Contents

<b>Release Control Record</b> .....	<b>3</b>
<b>1 Certificate of Conformity</b> .....	<b>4</b>
<b>2 Summary of Test Results</b> .....	<b>5</b>
2.1 Measurement Uncertainty .....	5
2.2 Modification Record .....	5
<b>3 General Information</b> .....	<b>6</b>
3.1 Description of EUT .....	6
3.2 Features of EUT .....	6
3.3 Test Program Used and Operation Descriptions.....	6
3.4 Primary Clock Frequencies of Internal Source .....	6
<b>4 Configuration and Connections with EUT</b> .....	<b>7</b>
4.1 Connection Diagram of EUT and Peripheral Devices.....	7
4.2 Configuration of Peripheral Devices and Cable Connections.....	8
<b>5 Conducted Emissions at Mains Ports</b> .....	<b>9</b>
5.1 Limits .....	9
5.2 Test Instruments .....	9
5.3 Test Arrangement .....	10
5.4 Test Results.....	11
<b>6 Radiated Emissions up to 1 GHz</b> .....	<b>13</b>
6.1 Limits .....	13
6.2 Test Instruments .....	13
6.3 Test Arrangement .....	14
6.4 Test Results.....	15
<b>7 Pictures of Test Arrangements</b> .....	<b>17</b>
7.1 Conducted Emissions at Mains Ports .....	17
7.2 Radiated Emissions up to 1 GHz .....	18
<b>Appendix – Information of the Testing Laboratories</b> .....	<b>19</b>

### Release Control Record

Issue No.	Description	Date Issued
FD200316D06	Original release.	Apr. 1, 2020

## 1 Certificate of Conformity

**Product:** Mini PCIe Digital I/O Card

**Brand:** Vecow

**Test Model:** DMX-110

**Series Model:** DMX-1 XXXXXXXXXXXXXXXX ("X" can be 0-9, A-Z or blank for marketing purpose)

**Sample Status:** Engineering sample

**Applicant:** Vecow Co., Ltd.

**Test Date:** Mar. 19 to 20, 2020

**Standards:** 47 CFR FCC Part 15, Subpart B, Class A  
ICES-003: 2016 Issue 6, updated Apr. 2019 Class A  
ANSI C63.4:2014

The above equipment has been tested by **Bureau Veritas Consumer Products Services (H.K.) Ltd., Taoyuan Branch**, and found compliance with the requirement of the above standards. The test record, data evaluation & Equipment Under Test (EUT) configurations represented herein are true and accurate accounts of the measurements of the sample's EMC characteristics under the conditions specified in this report.

**Prepared by :** Albee Chu , **Date:** Apr. 1, 2020  
Albee Chu / Specialist

**Approved by :** Jim Hsiang , **Date:** Apr. 1, 2020  
Jim Hsiang / Associate Technical Manager

## 2 Summary of Test Results

47 CFR FCC Part 15, Subpart B / ICES-003: 2016 Issue 6, updated Apr. 2019 Class A

ANSI C63.4:2014

FCC Clause	ICES-003 Clause	Test Item	Result/Remarks	Verdict
15.107	6.1	Conducted Emissions at mains ports	Minimum passing Class A margin is -4.92 dB at 0.25125 MHz	Pass
15.109	6.2.1	Radiated Emissions up to 1 GHz	Minimum passing Class A margin is -4.72 dB at 118.39 MHz	Pass
	6.2.2	Radiated Emissions above 1 GHz	EUT's highest frequency is below 108MHz	N/A

Note:

1. There is no deviation to the applied test methods and requirements covered by the scope of this report.
2. Determining compliance based on the results of the compliance measurement, not taking into account measurement instrumentation uncertainty.
3. N/A: Not Applicable.

### 2.1 Measurement Uncertainty

Where relevant, the following measurement uncertainty levels have been estimated for tests performed on the EUT:

Measurement	Frequency	Expanded Uncertainty (k=2) ( $\pm$ )
Conducted Emissions at mains ports	150kHz ~ 30MHz	2.94 dB
Radiated Emissions up to 1 GHz	30MHz ~ 1GHz	4.25 dB

### 2.2 Modification Record

There were no modifications required for compliance.

### 3 General Information

#### 3.1 Description of EUT

Product	Mini PCIe Digital I/O Card
Brand	Vecow
Test Model	DMX-110
Series Model	DMX-1 XXXXXXXXXXXXXXXX ("X" can be 0-9, A-Z or blank for marketing purpose)
Model Difference	Marketing purpose
Sample Status	Engineering sample
Operating Software	N/A
Power Supply Rating	DC power from IPC
Accessory Device	N/A
Data Cable Supplied	N/A

Note: The EUT is a Mini PCIe Digital I/O Card and installed in IPC during the test.

#### 3.2 Features of EUT

The tests reported herein were performed according to the method specified by Vecow Co., Ltd., for detailed feature description, please refer to the manufacturer's specifications or user's manual.

#### 3.3 Test Program Used and Operation Descriptions

- a. Installed the EUT into IPC.
- b. Turned on the power of all equipment.
- c. IPC ran a test program to enable all functions.
- d. IPC read and wrote messages from/to storage.
- e. IPC sent "H" patterns to ext. LCD Monitor. Then it displayed "H" patterns on its screen.
- f. IPC sent messages to printer and printer printed them out.
- g. IPC sent messages to modem.
- h. Steps d-g were repeated.

#### 3.4 Primary Clock Frequencies of Internal Source

The highest frequency generated or used within the EUT or on which the EUT operates or tunes is 8MHz, provided by Vecow Co., Ltd., for detailed internal source, please refer to the manufacturer's specifications.

#### 4 Configuration and Connections with EUT

##### 4.1 Connection Diagram of EUT and Peripheral Devices

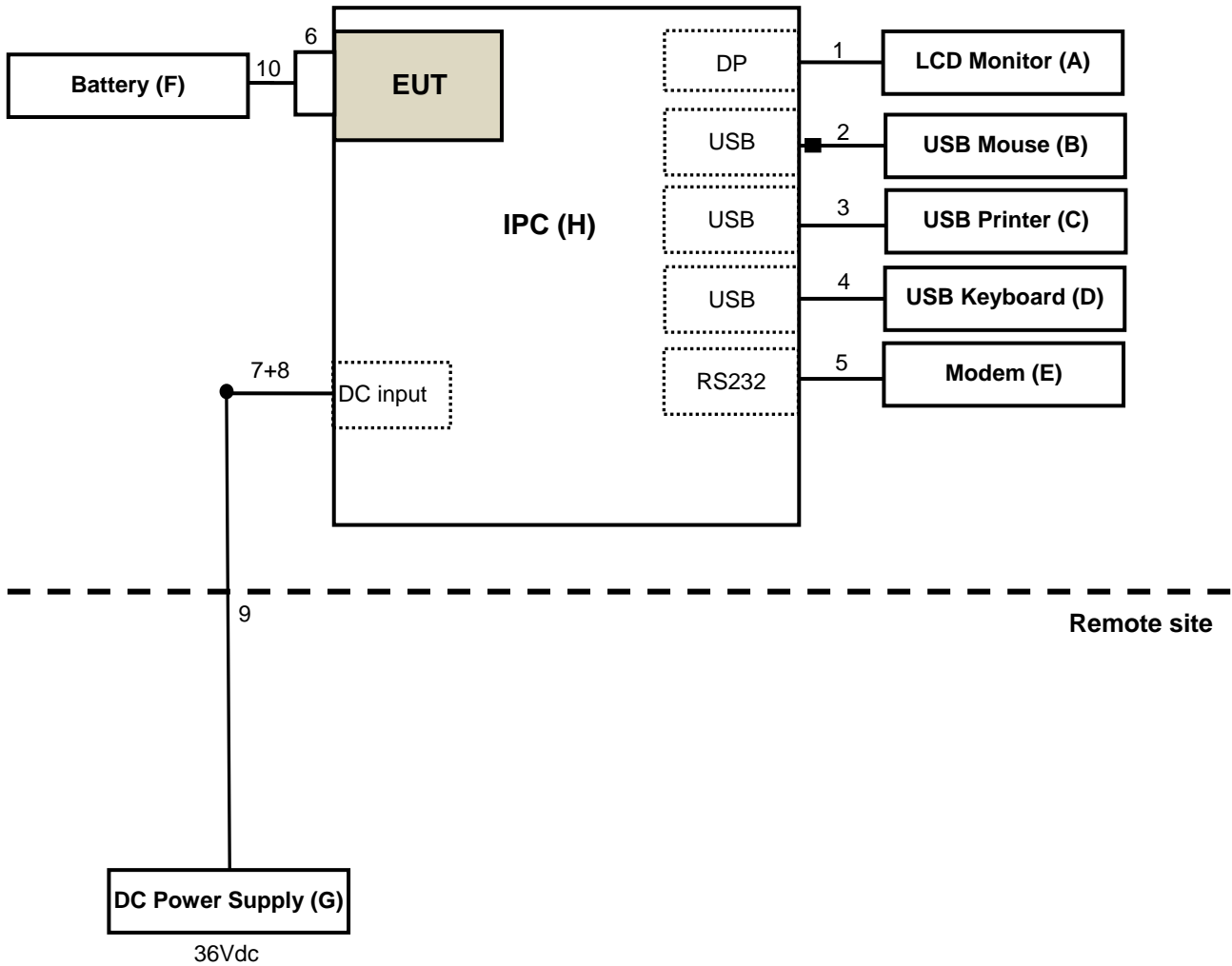

#### 4.2 Configuration of Peripheral Devices and Cable Connections

ID	Product	Brand	Model No.	Serial No.	FCC ID	Remarks
A.	LCD Monitor	ASUS	MG28U	H1LMTF041254	N/A	Provided by Lab
B.	USB Mouse	Microsoft	1113	9170528317887	FCC DoC Approved	Provided by Lab
C.	USB PRINTER	HP	HP Officejet Pro 251dw	N/A	N/A	Provided by Lab
D.	USB Keyboard	Dell	KB216t	CN-0W33XP-LO300-7C L-1919	N/A	Provided by Lab
E.	MODEM	ACEEX	1414	980020508	IFAXDM1414	Provided by Lab
F.	Battery	YUASA	NP7-12	N/A	N/A	Provided by Lab
G.	DC Power supply	CHROMA	62150H-600S	62150EC00479	N/A	Provided by Lab
H.	IPC	Vecow	RCS-9000	N/A	N/A	Supplied by client

Note: All power cords of the above support units are non-shielded (1.8m).

ID	Cable Descriptions	Qty.	Length (m)	Shielding (Yes/No)	Cores (Qty.)	Remarks
1.	Display cable	1	1.8	Y	0	Provided by Lab
2.	USB cable	1	1.8	Y	1	Provided by Lab
3.	USB cable	1	1.5	Y	0	Provided by Lab
4.	USB cable	1	1.8	Y	0	Provided by Lab
5.	RS232 cable	1	1.5	Y	0	Provided by Lab
6.	Connector	2	0.2	Y	0	Supplied by client
7.	DC cable	1	0.12	N	0	Supplied by client
8.	DC cable	1	1.8	N	0	Provided by Lab
9.	DC cable	1	10	N	0	Provided by Lab
10.	DC cable	2	0.6	N	0	Supplied by client

Note: The core(s) is(are) originally attached to the cable(s).



## 5 Conducted Emissions at Mains Ports

### 5.1 Limits

Frequency (MHz)	Class A (dBuV)		Class B (dBuV)	
	Quasi-peak	Average	Quasi-peak	Average
0.15 - 0.5	79	66	66 - 56	56 - 46
0.50 - 5.0	73	60	56	46
5.0 - 30.0	73	60	60	50

Notes: 1. The lower limit shall apply at the transition frequencies.  
 2. The limit decreases linearly with the logarithm of the frequency in the range of 0.15 to 0.50 MHz.

### 5.2 Test Instruments

Description & Manufacturer	Model No.	Serial No.	Cal. Date	Cal. Due
ROHDE & SCHWARZ TEST RECEIVER	ESR3	102413	Feb. 17, 2020	Feb. 16, 2021
ROHDE & SCHWARZ Artificial Mains Network (for EUT)	ESH2-Z5	100104	Dec. 13, 2019	Dec. 12, 2020
LISN With Adapter (for EUT)	AD10	C09Ada-001	Dec. 13, 2019	Dec. 12, 2020
ROHDE & SCHWARZ Artificial Mains Network (for peripherals)	ESH3-Z5	847265/023	Oct. 31, 2019	Oct. 30, 2020
SCHWARZBECK Artificial Mains Network (For EUT)	NNLK8129	8129229	May 14, 2019	May 13, 2020
SCHWARZBECK Artificial Mains Network (for EUT)	NSLK 8128	8128-244	Nov. 11, 2019	Nov. 10, 2020
Software	Cond_V7.3.7.4	NA	NA	NA
RF cable (JYEBAO) With 10dB PAD	5D-FB	Cable-C09.01	Aug. 15, 2019	Aug. 14, 2020
SUHNER Terminator (For ROHDE & SCHWARZ LISN)	65BNC-5001	E1-010789	May 13, 2019	May 12, 2020

Note: 1. The calibration interval of the above test instruments is 12 months and the calibrations are traceable to NML/ROC and NIST/USA.  
 2. The test was performed in Shielded Room No. 9.  
 3. The VCCI Site Registration No. C-11312.  
 4. Tested Date: Mar. 19, 2020

### 5.3 Test Arrangement

- The EUT was placed 0.4 meters from the conducting wall of the shielded room with EUT being connected to the power mains through a line impedance stabilization network (LISN). Other support units were connected to the power mains through another LISN. The two LISNs provide 50 Ohm/ 50uH of coupling impedance for the measuring instrument.
- Both lines of the power mains connected to the EUT were checked for maximum conducted interference.
- The test results of conducted emissions at mains ports are recorded of six worst margins for quasi-peak (mandatory) [and average (if necessary)] values against the limits at frequencies of interest unless the margin is 20 dB or greater.

Note: The resolution bandwidth and video bandwidth of test receiver is 9kHz for quasi-peak detection (QP) and average detection (AV) at frequency 0.15MHz-30MHz.

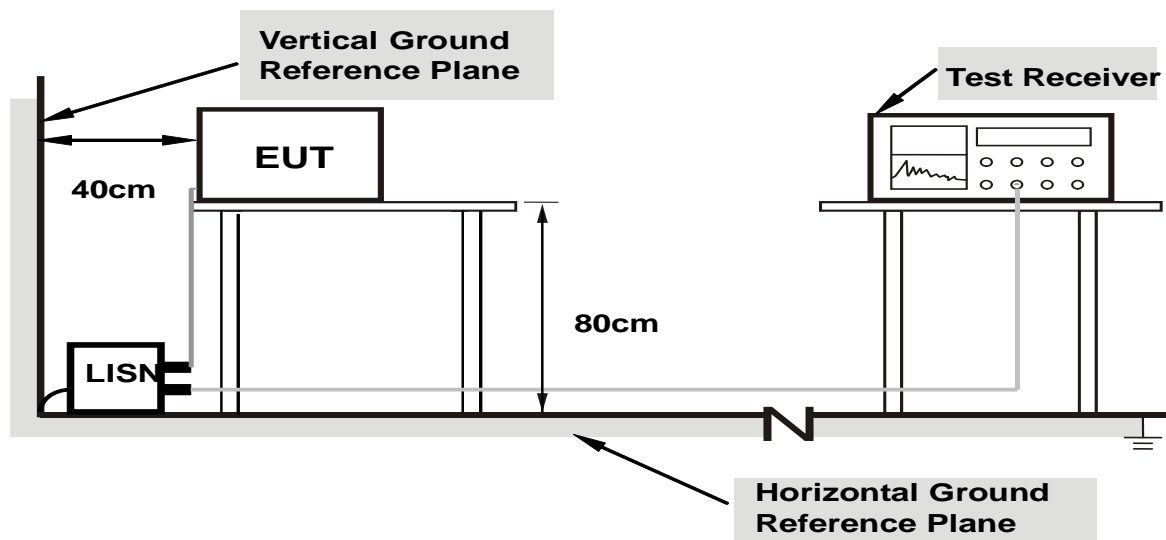

**Note: Support units were connected to second LISN.**

For the actual test configuration, please refer to the related item – Photographs of the Test Configuration.

### 5.4 Test Results

Frequency Range	150kHz ~ 30MHz	Detector Function & Resolution Bandwidth	Quasi-Peak (QP) / Average (AV), 9kHz
Input Power (System)	36Vdc	Environmental Conditions	21°C, 70%RH
Tested by	Chenghan Wu		
Test Mode	Operating		

Phase Of Power : Positive (+)										
No	Frequency (MHz)	Correction Factor (dB)	Reading Value (dBuV)		Emission Level (dBuV)		Limit (dBuV)		Margin (dB)	
			Q.P.	AV.	Q.P.	AV.	Q.P.	AV.	Q.P.	AV.
1	0.25125	10.40	56.28	50.68	66.68	61.08	79.00	66.00	-12.32	-4.92
2	0.49977	10.40	53.15	46.26	63.55	56.66	79.00	66.00	-15.45	-9.34
3	0.64467	10.39	46.85	31.38	57.24	41.77	73.00	60.00	-15.76	-18.23
4	0.78934	10.39	47.57	40.16	57.96	50.55	73.00	60.00	-15.04	-9.45
5	0.99657	10.38	46.69	37.59	57.07	47.97	73.00	60.00	-15.93	-12.03
6	1.28591	10.39	45.92	39.32	56.31	49.71	73.00	60.00	-16.69	-10.29
7	1.49696	10.39	45.92	38.35	56.31	48.74	73.00	60.00	-16.69	-11.26

**Remarks:**

1. Q.P. and AV. are abbreviations of quasi-peak and average individually.
2. The emission levels of other frequencies were very low against the limit.
3. Margin value = Emission level – Limit value
4. Correction factor = Insertion loss + Cable loss
5. Emission Level = Correction Factor + Reading Value

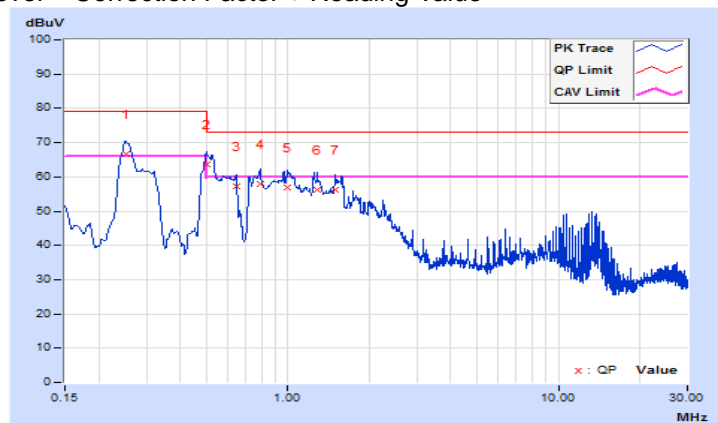

Frequency Range	150kHz ~ 30MHz	Detector Function & Resolution Bandwidth	Quasi-Peak (QP) / Average (AV), 9kHz
Input Power (System)	36Vdc	Environmental Conditions	21°C, 70%RH
Tested by	Chenghan Wu		
Test Mode	Operating		

Phase Of Power : Negative (-)										
No	Frequency (MHz)	Correction Factor (dB)	Reading Value (dBuV)		Emission Level (dBuV)		Limit (dBuV)		Margin (dB)	
			Q.P.	AV.	Q.P.	AV.	Q.P.	AV.	Q.P.	AV.
1	0.24775	10.40	42.02	35.52	52.42	45.92	79.00	66.00	-26.58	-20.08
2	0.33246	10.41	43.16	42.08	53.57	52.49	79.00	66.00	-25.43	-13.51
3	0.49845	10.41	42.82	36.01	53.23	46.42	79.00	66.00	-25.77	-19.58
4	0.78934	10.39	41.46	34.30	51.85	44.69	73.00	60.00	-21.15	-15.31
5	0.96529	10.38	43.67	29.57	54.05	39.95	73.00	60.00	-18.95	-20.05
6	1.24681	10.39	42.42	34.94	52.81	45.33	73.00	60.00	-20.19	-14.67
7	1.49605	10.40	42.39	34.86	52.79	45.26	73.00	60.00	-20.21	-14.74

**Remarks:**

1. Q.P. and AV. are abbreviations of quasi-peak and average individually.
2. The emission levels of other frequencies were very low against the limit.
3. Margin value = Emission level – Limit value
4. Correction factor = Insertion loss + Cable loss
5. Emission Level = Correction Factor + Reading Value

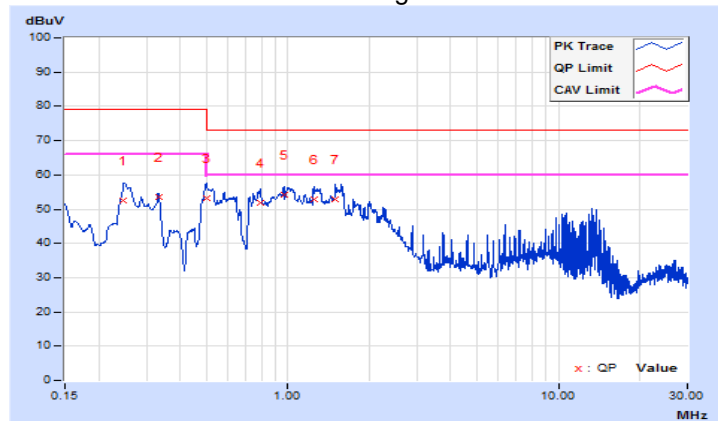

## 6 Radiated Emissions up to 1 GHz

### 6.1 Limits

Emissions radiated outside of the specified bands, shall be according to the general radiated limits as following:

Radiated Emissions Limits at 10 meters (dB $\mu$ V/m)				
Frequencies (MHz)	FCC 15B / ICES-003, Class A	FCC 15B / ICES-003, Class B	CISPR 22, Class A	CISPR 22, Class B
30-88	39	29.5	40	30
88-216	43.5	33.1		
216-230	46.4	35.6		
230-960				
960-1000	49.5	43.5	47	37

Radiated Emissions Limits at 3 meters (dB $\mu$ V/m)				
Frequencies (MHz)	FCC 15B / ICES-003, Class A	FCC 15B / ICES-003, Class B	CISPR 22, Class A	CISPR 22, Class B
30-88	49.5	40	50.5	40.5
88-216	54	43.5		
216-230	56.9	46		
230-960				
960-1000	60	54	57.5	47.5

- Notes:
1. The lower limit shall apply at the transition frequencies.
  2. Emission level (dB $\mu$ V/m) = 20 log Emission level (uV/m).
  3. QP detector shall be applied if not specified.

### 6.2 Test Instruments

Description & Manufacturer	Model No.	Serial No.	Cal. Date	Cal. Due
ROHDE & SCHWARZ TEST RECEIVER	ESCS 30	100027	May 13, 2019	May 12, 2020
Schwarzbeck Bilog Antenna	VULB9168	9168-303	Nov. 11, 2019	Nov. 10, 2020
Agilent Preamplifier	8447D	2944A08119	Feb. 19, 2020	Feb. 18, 2021
ADT. Turn Table	TT100	0205	NA	NA
ADT. Tower	AT100	0205	NA	NA
Software	Radiated_V7.6.15.9.5	NA	NA	NA
ADT RF Switches BOX	EMH-011	1001	Oct. 24, 2019	Oct. 23, 2020
Pacific RF cable With 5dB PAD	8D	CABLE-ST2-01	Oct. 24, 2019	Oct. 23, 2020

- Note:
1. The calibration interval of the above test instruments is 12 months and the calibrations are traceable to NML/ROC and NIST/USA.
  2. The test was performed in Open Site No. 2.
  3. The VCCI Site Registration No. R-10237.
  4. Tested Date: Mar. 20, 2020

### 6.3 Test Arrangement

- The EUT was placed on the top of a rotating table 0.8 meters above the ground at an accredited test facility. The table was rotated 360 degrees to determine the position of the highest radiation.
- The EUT was set 10 meters away from the interference-receiving antenna, which was mounted on the top of a variable-height antenna tower.
- The antenna is a broadband antenna, and its height is varied from one meter to four meters above the ground to determine the maximum value of the field strength. Both horizontal and vertical polarizations of the antenna are set to make the measurement.
- For each suspected emission, the EUT was arranged to its worst case and then the antenna was tuned to heights from 1 meter to 4 meters and the rotatable table was turned from 0 degrees to 360 degrees to find the maximum reading.
- The test-receiver system was set to quasi-peak detect function and specified bandwidth with maximum hold mode when the test frequency is up to 1 GHz.

Note: The resolution bandwidth and video bandwidth of test receiver/spectrum analyzer is 120kHz for quasi-peak detection (QP) at frequency up to 1GHz.

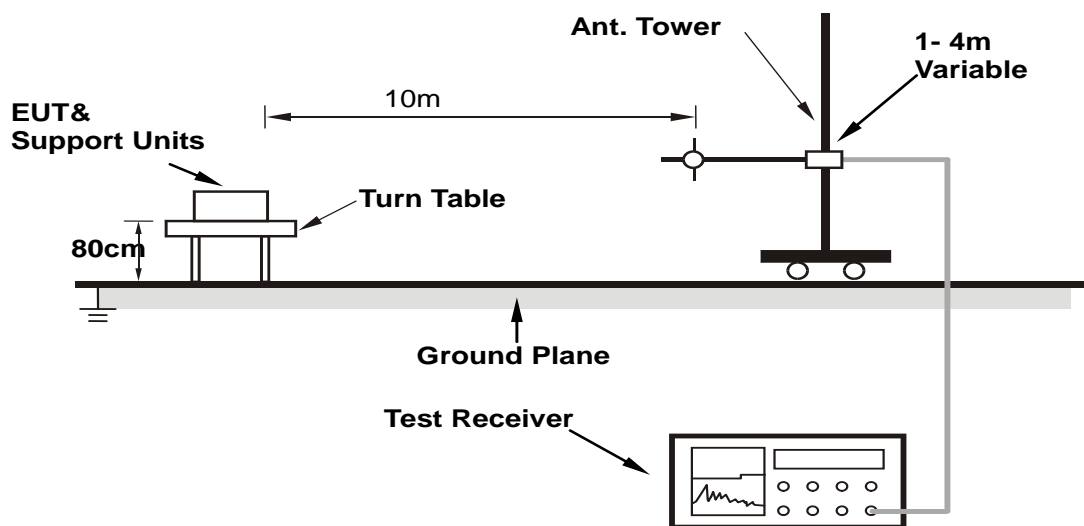

For the actual test configuration, please refer to the related item – Photographs of the Test Configuration.

### 6.4 Test Results

<b>Frequency Range</b>	30MHz ~ 1GHz	<b>Detector Function &amp; Resolution Bandwidth</b>	Quasi-Peak (QP), 120kHz
<b>Input Power (System)</b>	36Vdc	<b>Environmental Conditions</b>	22°C, 73%RH
<b>Tested by</b>	Paul Chen		
<b>Test Mode</b>	Operating		

Antenna Polarity & Test Distance : Horizontal at 10 m								
No	Frequency (MHz)	Emission Level (dBuV/m)	Limit (dBuV/m)	Margin (dB)	Antenna Height (m)	Table Angle (Degree)	Raw Value (dBuV)	Correction Factor (dB/m)
1	50.16	27.50 QP	40.00	-12.50	4.00 H	30	37.25	-9.75
<b>2</b>	<b>118.39</b>	<b>35.28 QP</b>	<b>40.00</b>	<b>-4.72</b>	<b>4.00 H</b>	<b>278</b>	<b>47.06</b>	<b>-11.78</b>
3	154.24	29.62 QP	40.00	-10.38	4.00 H	287	38.68	-9.06
4	182.00	24.50 QP	40.00	-15.50	4.00 H	46	35.44	-10.94
5	220.24	27.35 QP	40.00	-12.65	4.00 H	177	39.05	-11.70
6	354.07	32.81 QP	47.00	-14.19	3.11 H	82	39.23	-6.42
7	672.45	31.63 QP	47.00	-15.37	1.44 H	293	31.38	0.25

Remarks:

1. Emission Level(dBuV/m) = Raw Value(dBuV) + Correction Factor(dB/m)
2. Correction Factor(dB/m) = Antenna Factor (dB/m) + Cable Factor (dB) – Pre-Amplifier Factor (dB)
3. The other emission levels were very low against the limit.
4. Margin value = Emission level – Limit value

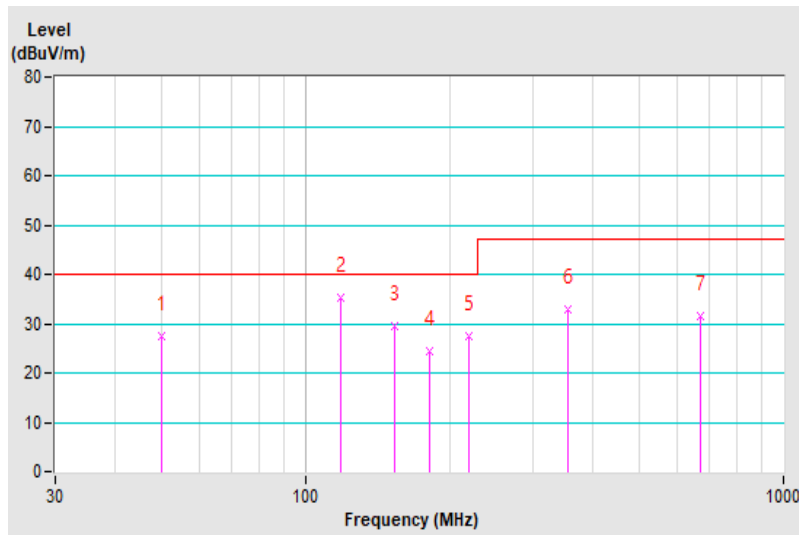

<b>Frequency Range</b>	30MHz ~ 1GHz	<b>Detector Function &amp; Resolution Bandwidth</b>	Quasi-Peak (QP), 120kHz
<b>Input Power (System)</b>	36Vdc	<b>Environmental Conditions</b>	22°C, 73%RH
<b>Tested by</b>	Paul Chen		
<b>Test Mode</b>	Operating		

Antenna Polarity & Test Distance : Vertical at 10 m								
No	Frequency (MHz)	Emission Level (dBuV/m)	Limit (dBuV/m)	Margin (dB)	Antenna Height (m)	Table Angle (Degree)	Raw Value (dBuV)	Correction Factor (dB/m)
1	31.59	30.19 QP	40.00	-9.81	1.13 V	92	41.69	-11.50
2	63.49	30.61 QP	40.00	-9.39	1.42 V	163	41.46	-10.85
3	118.71	34.44 QP	40.00	-5.56	1.00 V	297	46.22	-11.78
4	151.20	28.80 QP	40.00	-11.20	1.00 V	107	38.03	-9.23
5	203.48	25.45 QP	40.00	-14.55	1.00 V	193	37.68	-12.23
6	341.21	31.89 QP	47.00	-15.11	1.00 V	38	38.60	-6.71
7	649.09	32.58 QP	47.00	-14.42	3.10 V	145	32.72	-0.14

Remarks:

1. Emission Level(dBuV/m) = Raw Value(dBuV) + Correction Factor(dB/m)
2. Correction Factor(dB/m) = Antenna Factor (dB/m) + Cable Factor (dB) – Pre-Amplifier Factor (dB)
3. The other emission levels were very low against the limit.
4. Margin value = Emission level – Limit value

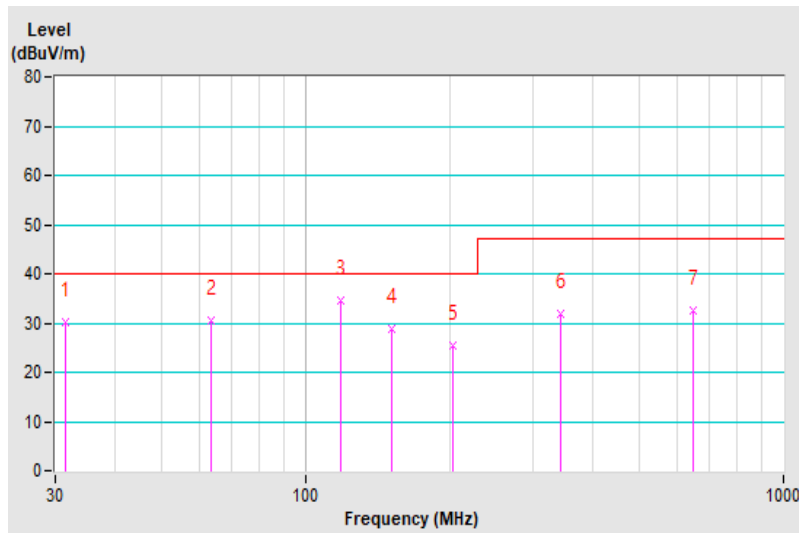



## 7 Pictures of Test Arrangements

### 7.1 Conducted Emissions at Mains Ports

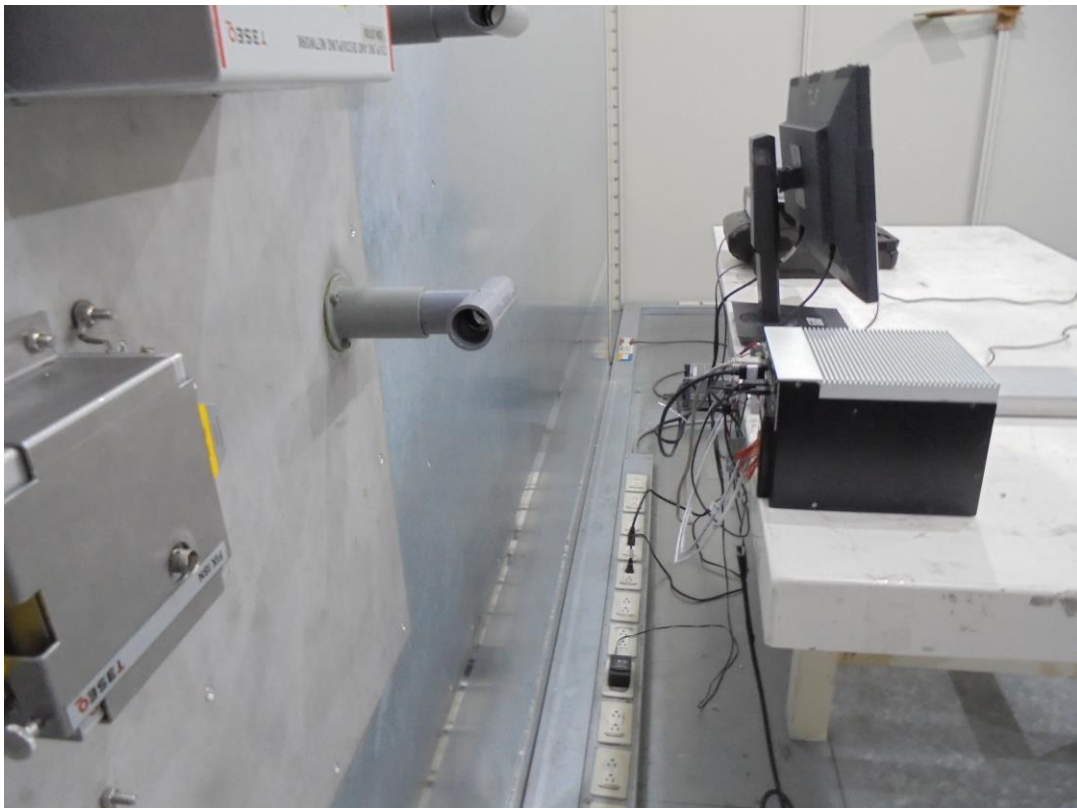

## 7.2 Radiated Emissions up to 1 GHz



## Appendix – Information of the Testing Laboratories

We, Bureau Veritas Consumer Products Services (H.K.) Ltd., Taoyuan Branch, were founded in 1988 to provide our best service in EMC, Radio, Telecom and Safety consultation. Our laboratories are FCC recognized accredited test firms and accredited according to ISO/IEC 17025.

If you have any comments, please feel free to contact us at the following:

**Lin Kou EMC/RF Lab**

Tel: 886-2-26052180

Fax: 886-2-26051924

**Hsin Chu EMC/RF/Telecom Lab**

Tel: 886-3-6668565

Fax: 886-3-6668323

**Hwa Ya EMC/RF/Safety Lab**

Tel: 886-3-3183232

Fax: 886-3-3270892

**Email:** [service.adt@tw.bureauveritas.com](mailto:service.adt@tw.bureauveritas.com)

**Web Site:** [www.bureauveritas-adt.com](http://www.bureauveritas-adt.com)

The address and road map of all our labs can be found in our web site also.

--- END ---